



DEFENDER™ 3000

Bench Scales



Bench Scales for Basic Industrial Applications

The Defender 3000 Series bench scales are ideal for general weighing, simple counting and checkweighing applications in production, packaging, warehouse, inventory, shipping and receiving areas. The Defender 3000 Series features a simple, yet rugged tubular-frame base design and indicators with tactile keys, multicolor backlit LCD display, AC or rechargeable battery operation and flexible mounting capabilities.

Unique Features:

- Results are clearly shown using the large, bright backlit LCD display. In Checkweighing mode display changes color (yellow/green/red) to alert when within the target weight range.
- This tough industrial scale features a 304-stainless steel platform, powder-coated steel tubular frame, column and aluminum load cell. Indicator features a durable ABS housing and powder coated steel mounting bracket.
- Features software for Parts Counting, Checkweighing and Totalization. Includes RS232 with optional USB Device or Ethernet for printing or data connectivity.

DEFENDER™ 3000 Bench Scales

Specifications

Column Mount Bench Scale

| Model | i-D33P15B1R1 | i-D33P30B1R1 | i-D33P60B1R1 | i-D33P60B1L2 | i-D33P150B1L2 |
|--|---|--------------|--------------|---|---------------|
| Capacity x Default Readability | 15 kg x 1 g | 30 kg x 2 g | 60 kg x 5 g | | 150 kg x 10 g |
| Maximum Displayed Resolution | 1:15,000 | | 1:12,000 | | 1:15,000 |
| Linearity/Repeatability | ±2d | | | | |
| Indicator | ABS indicator | | | | |
| Column | 330 mm powder-coated steel | | | 680 mm powder-coated steel | |
| Base Construction | Stainless steel removable weighing platform, powder-coated steel base construction, aluminum loadcell silicon sealed against moisture | | | | |
| Safe Overload Capacity | 150% of maximum capacity | | | | |
| Stabilization Time | Within 1 second | | | | |
| Operating Temperature Range | -10°C to 40°C | | | | |
| Scale Dimensions (A x B x C x D x E x F) | 355 x 305 x 121.8 x 75 x 541.6 x 489.1 mm | | | 550 x 420 x 134 x 80 x 896.1 x 685.6 mm | |
| Shipping Dimensions (L x W x H) | 642 x 497 x 212 mm | | | 857 x 564 x 225 mm | |
| Approx. Net Weight | 10.9 kg | | | 17.5 kg | |
| Approx. Shipping Weight | 13.9 kg | | | 21.5 kg | |

| Model | i-D33P150B1X2 | i-D33P300B1X2 | i-D33P300B1V3 | i-D33P600B1V3 |
|--|---|---------------|--|---------------|
| Capacity x Default Readability | 150 kg x 10 g | 300 kg x 20 g | 300 kg x 20 g | 600 kg x 50 g |
| Maximum Displayed Resolution | 1:15,000 | | | 1:12,000 |
| Linearity/Repeatability | ±2d | | | |
| Indicator | ABS indicator | | | |
| Column | 680 mm powder-coated steel | | 980 mm powder-coated steel | |
| Base Construction | Stainless steel removable weighing platform, powder-coated steel base construction, aluminum loadcell silicon sealed against moisture | | | |
| Safe Overload Capacity | 150% of maximum capacity | | | |
| Stabilization Time | Within 1 second | | | |
| Operating Temperature Range | -10°C to 40°C | | | |
| Scale Dimensions (A x B x C x D x E x F) | 650 x 500 x 150 x 90 x 894.6 x 784.6 mm | | 800 x 600 x 154.1 x 90 x 1194.6 x 933.1 mm | |
| Shipping Dimensions (L x W x H) | 1022 x 687 x 247 mm | | 1165 x 780 x 235 mm | |
| Approx. Net Weight | 27.6 kg | | 46 kg | |
| Approx. Shipping Weight | 31.1 kg | | 50 kg | |

DEFENDER™ 3000 Bench Scales

Specifications

Front Mount Bench Scale

| Model | i-D33P15B1R5 | i-D33P30B1R5 | i-D33P60B1R5 | i-D33P60B1L5 | i-D33P150B1L5 | i-D33P150B1X5 | i-D33P300B1X5 |
|--|---|--------------|--------------|---------------------------------------|---------------|-------------------------------------|---------------|
| Capacity x Default Readability | 15 kg x 1 g | 30 kg x 2 g | 60 kg x 5 g | | 150 kg x 10 g | | 300 kg x 20 g |
| Maximum Displayed Resolution | 1:15,000 | | 1:12,000 | | 1:15,000 | | |
| Linearity/Repeatability | ±2d | | | | | | |
| Indicator | ABS indicator | | | | | | |
| Mount | 304 stainless steel front-mount bracket with handle | | | | | | |
| Base Construction | Stainless steel removable weighing platform, powder-coated steel base construction, aluminum loadcell silicon sealed against moisture | | | | | | |
| Safe Overload Capacity | 150% of maximum capacity | | | | | | |
| Stabilization Time | Within 1 second | | | | | | |
| Operating Temperature Range | -10°C to 40°C | | | | | | |
| Scale Dimensions (A x B x C x D x E x F) | 355 x 305 x 121.8 x 75 x 130 x 645.5 mm | | | 550 x 420 x 134 x 80 x 132.9 x 842 mm | | 650 x 500 x 150 x 90 x 133 x 941 mm | |
| Shipping Dimensions (L x W x H) | 857 x 564 x 225 mm | | | 1022 x 687 x 247 mm | | 1022 x 687 x 247 mm | |
| Approx. Net Weight | 10.2 kg | | | 16.1 kg | | 26.2kg | |
| Approx. Shipping Weight | 12.5 kg | | | 20.1 kg | | 29.7 kg | |

Indicators

| Model | i-DT33P |
|--------------------|--|
| Construction | ABS housing, painted steel mounting bracket |
| Protection Rate | IP54 with dust cover |
| Weighing Units | Kilogram, Gram, Pound, Ounce, Pound: Ounce |
| Application Modes | Weighing, Parts Counting, Checkweighing and Totalization |
| Display | 6-digit, 7-segment LCD display with multi-color backlight, 45 mm high digits |
| Check Indicator | 3 Color (red, green, yellow) backlight |
| Keyboard | 4 function keys |
| Auto-zero Tracking | Off, 0.5 d, 1 d or 3 d |
| Zeroing Range | 2% or 100% of capacity |
| Interface | RS232 included, Optional USB, Ethernet |
| Power | 100-240 VAC / 50/60 Hz Universal Power Supply or Standard Rechargeable battery |
| Battery Life | Up to 100 hours continuous use with backlight off |
| Calibration | Zero, Span or 3 point-Linear |

DEFENDER™ 3000 Bench Scales

Outline Dimensions

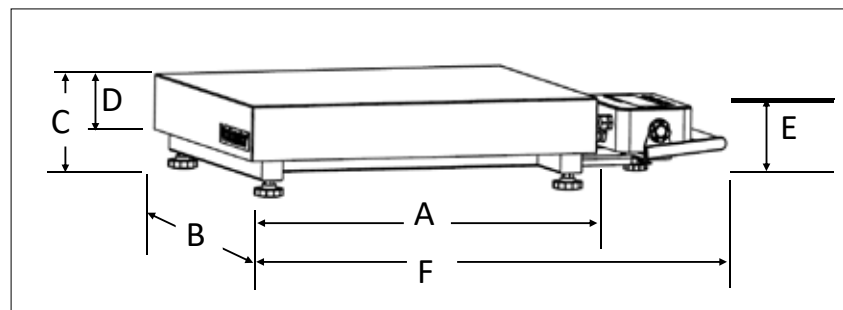
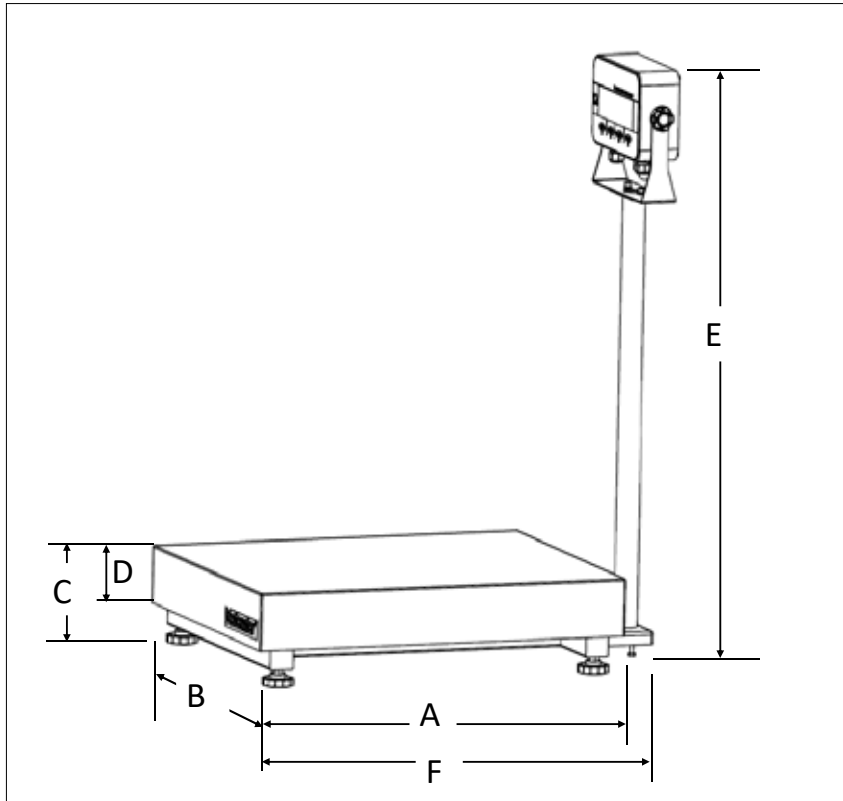

Accessories

| | |
|---------------------------------------|----------|
| Ethernet Kit. | 30429666 |
| USB Device Kit i-DT33. | 30699120 |
| Dust Cover (5) i-DT33. | 30699121 |
| Wheel Kit, Defender Series. | 30372146 |
| Wheel Kit SST Defender Series. | 30616409 |
| Carrying Handle Kit, SST i-DT33. | 30696600 |
| SF40A Printer. | 30045641 |
| Cable RS232 i-DT33P. | 80500525 |

Column Kit for i-DT33 indicator:

| | |
|-------------------------------|----------|
| Column Kit, 330 mm, SST. | 30696595 |
| Column Kit, 680 mm, SST. | 30696596 |
| Column Kit, 330 mm, CS. | 30696597 |
| Column Kit, 680 mm, CS. | 30696598 |
| Column Kit, 980 mm, CS. | 30696599 |

Column Kit for DT52 indicator:

| | |
|-------------------------------|----------|
| Column Kit, 350 mm, CS. | 30424410 |
| Column Kit, 680 mm, CS. | 30424411 |
| Column Kit, 980 mm, CS. | 30424412 |
| Column Kit, 350 mm, SST. | 30424413 |
| Column Kit, 680 mm, SST. | 30424414 |

Compliance

- **Product Safety:** IEC/EN 61010-1; CAN/CSA C22.2 61010-1; UL61010-1
- **Electromagnetic Compatibility:** IEC/EN 61326-1 Class B, basic environments; FCC Part 15 Class A; Canada ICES-003 Class A
- **Ingress Protection:** IEC 60529 – IP54 (for indicator with dust cover), IEC 60529 – IP65 (for load cell)
- **Compliance Marks:** CE, UKCA
- **Other:** WEEE, RoHS

OHAUS Asia/Pacific Headquarters
 7F, Block 33, 680 Guiping Road
 Shanghai 200233
 China
 e-mail: APmarketing@ohaus.com
 Tel: +86 21 64855408

With offices throughout Europe, Asia, and Latin America

* **ISO 9001:2008**
 Registered Quality Management System
 SAP Literature # 30760676

